



Single Precast Reinforced Concrete Box Culvert Standards

General Notes:

- The precast RCB culvert sections are designed for HL-93 live load and earth fills of varying heights.
- Vertical earth pressure, $EV=0.120$ kcf. Horizontal earth pressure, $EH_{max} = 0.060$ kcf max, $EH_{min} = 0.030$ kcf.
- The precast RCB culvert sections are designed for class 2 exposure conditions.
- The clear distance from face of concrete to near edge or end of reinforcing bar to be $1\frac{1}{2}$ " min. and 2" max. unless otherwise noted.
- The reinforcement supplied for this structure shall be plain and/or deformed welded wire reinforcement (WWR) $F_y = 65$ ksi, and/or Grade 60 reinforcing steel in accordance with the standard specifications. The reinforcement areas are based on welded wire reinforcement. If reinforcing bars are substituted for welded wire reinforcement, the reinforcement areas shall be increased by 8%. The barrel sections in these standards were designed with plain WWR, $F_y = 65$ ksi.
- All dimensions are in feet and inches unless otherwise noted or shown.
- Any of the following combinations of reinforcement may be used:
 - 1 or 2 layers of welded wire reinforcement or
 - 1 layer of welded wire reinforcement and 1 layer of reinforcement bars or
 - 1 layer of reinforcement bars.
 The reinforcement shall be developed in accordance with AASHTO LRFD specifications.
- The maximum size of reinforcement bars shall be #6, except for parapet reinforcement as detailed.
- The maximum welded wire reinforcement size shall be a W23/D23 per layer (maximum of 2 layers).
- The spacing center to center of the transverse wires or bars shall not be less than 2" nor more than 4". The spacing center to center of the longitudinal wires or bars shall not be more than 8".
- Welding will not be allowed on reinforcement bars or welded wire reinforcement, except that the original welding required to manufacture the wire reinforcement is acceptable.
- When reinforcement is cut, additional reinforcement shall be added on both sides of the cut member to replace or exceed the cut reinforcement.
- Eriksson Culvert software version 4.3.1.0 was used for the design of the barrel sections for these standards.
- These culvert standards label all reinforcing steel with English notation (#3 is $\frac{3}{8}$ inch diameter bar). English reinforcing steel received at the precast plant may display the following "bar designation". The "bar designation" is the stamped impression on the reinforcing bars, and is equivalent to the bar diameter in millimeters.

English Size	3	4	5	6	7	8	9	10	11
Bar Designation	10	13	16	19	22	25	29	32	36

- The first precast barrel section adjacent to the outlet precast end section may be a double groove barrel to facilitate placement of outlet end sections and allow inlet and outlet end sections to be similar.

Index for Precast Culvert Standards:

PRCB G1-20	Index & General Notes
PRCB G2-20	Typical Culvert Barrel Details
PRCB 6-20	Culvert Barrel Details, 6' Spans
PRCB 8-20	Culvert Barrel Details, 8' Spans
PRCB 10-20	Culvert Barrel Details, 10' Spans
PRCB 12-20	Culvert Barrel Details, 12' Spans
PRCB 14-20	Culvert Barrel Details, 14' Spans
PRCB 16-20	Culvert Barrel Details, 16' Spans
PES 1-20-T1	Type 1 End Section Details, Up to 7.5° Skews, 6' to 12' Spans, Sheet 1 of 2
PES 2-20-T1	Type 1 End Section Details, Up to 7.5° Skews, 6' to 12' Spans, Sheet 2 of 2
PES 3-20-T1	Type 1 End Section Details, Up to 7.5° Skews, 14' to 16' Spans, Sheet 1 of 2
PES 4-20-T1	Type 1 End Section Details, Up to 7.5° Skews, 14' to 16' Spans, Sheet 2 of 2
PES 1-20-T3	Type 3 End Section Details, Up to 7.5° Skews, 6' to 12' Spans, Sheet 1 of 2
PES 2-20-T3	Type 3 End Section Details, Up to 7.5° Skews, 6' to 12' Spans, Sheet 2 of 2
PES 3-20-T3	Type 3 End Section Details, Up to 7.5° Skews, 14' to 16' Spans, Sheet 1 of 2
PES 4-20-T3	Type 3 End Section Details, Up to 7.5° Skews, 14' to 16' Spans, Sheet 2 of 2
PES 5-20-T3	Type 3 End Section Details, 7.5° to 45° Skews, 6' to 12' Spans, Sheet 1 of 2
PES 6-20-T3	Type 3 End Section Details, 7.5° to 45° Skews, 6' to 12' Spans, Sheet 2 of 2
PES 7-20-T3	Type 3 End Section Details, 7.5° to 45° Skews, 14' to 16' Spans, Sheet 1 of 2
PES 8-20-T3	Type 3 End Section Details, 7.5° to 45° Skews, 14' to 16' Spans, Sheet 2 of 2
PES 9-20-T3	Type 3 Lintel Beam Details, 0° to 45° Skews, 6' to 12' Spans
PES 10-20-T3	Type 3 Lintel Beam Details, 0° to 45° Skews, 14' to 16' Spans
PES 11-20	Alternate Curtain Wall Details
PEP 12-20	Embankment Protection Details, 0° to 45° Skews

Specifications:

Design:
AASHTO LRFD Bridge Design Specifications, 8th Ed., Series of 2017.

Construction:
Iowa Department of Transportation Standard Specifications for Highway and Bridge Construction, current series, plus applicable General Supplemental Specifications, Developmental Specifications, Supplemental Specifications and Special Provisions

Design Stresses:

Design stresses for the following materials are in accordance with the AASHTO LRFD Bridge Design Specifications, 8th Ed., Series of 2017:
Bar reinforcement in accordance with AASHTO LRFD Section 5, Grade 60. Welded wire reinforcement in accordance with AASHTO LRFD Section 5. Concrete in accordance with AASHTO LRFD Section 5, f'_c for barrel sections as noted on culvert barrel detail standards, for end section design $f'_c = 5$ ksi.

ENGLISHIGNEDPRECASTCULVERTS.DGN - PRCB G1-20 - THIS SHEET ISSUED 12-2020.

M:\Manzer P:\Projects\DM2142305960\Deliverables\Drawings1_Civil\plans\IV_Bridge and Culvert Situation Plans\IV-SHEETS.dgn 11/14/2024 2:59:55 PM

LATEST REVISION DATE	APPROVED BY BRIDGE ENGINEER		
		Standard Design Single Precast Reinforced Concrete Box Culverts December, 2020	
		Index and General Notes	PRCB G1-20

12/28/2022 12:39:52 PM bkloss p:\NTP\int1.dot.int.lan:PwMain\Documents\Highway\Bridges\Standards Development V81\Culverts\EnglishSignedPrecastCulverts.dgn PRCB G1-20 11x17.pdf.pltcfp

NO.	REVISION DESCRIPTION	APPROVED	DATE

M:\Manzer P:\Projects\DM2142305960\Deliverables\Drawings1_Civil\plans\IV_Bridge and Culvert Situation Plans\IV-SHEETS.dgn 11/14/2024 3:00:03 PM

REVISED 10-2021: Updated Note 3.
 REVISED 01-2023: Added note to burr threads of Concrete Box Ties.
 ENGLISHIGNEDPRECASTCULVERTS.DGN - PRCB G2-20 - THIS SHEET ISSUED 12-2020.

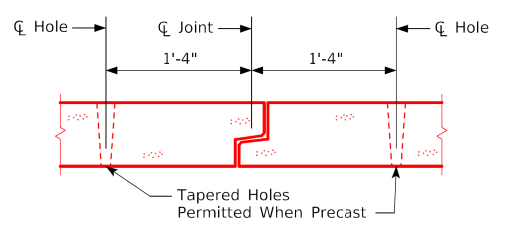

Typical Tie Layout

Note:
 Holes shall be cast or drilled 1'-4" from centerline of joints as shown above, unless forms are set up for 1'-4" spacing from outside of joint.

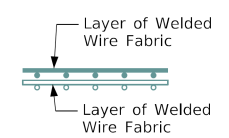

Fabric Layer Detail

Note:
 When more than one layer of welded wire fabric is used to obtain the required reinforcement areas, the wires of the welded wire fabric shall be placed as shown.

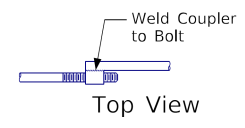

Top View

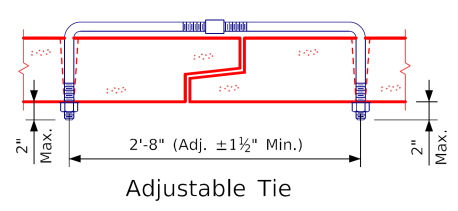

Adjustable Tie

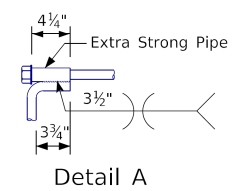

Detail A

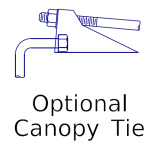

Optional Canopy Tie

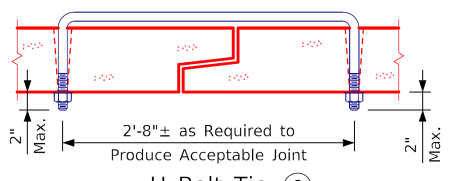

U Bolt Tie (6)

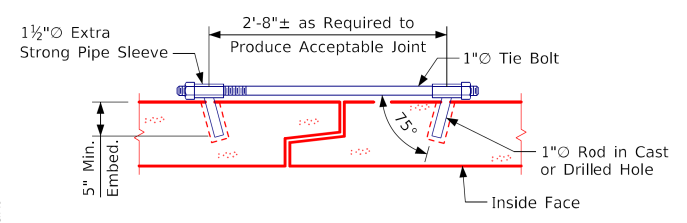

Concealed Double Welded Pipe Tie

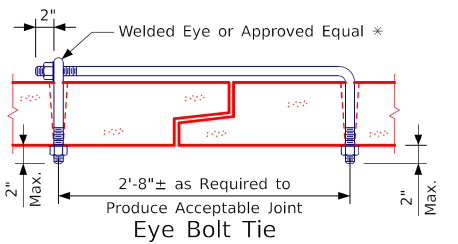

Eye Bolt Tie

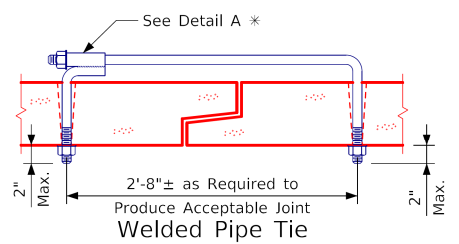

Welded Pipe Tie

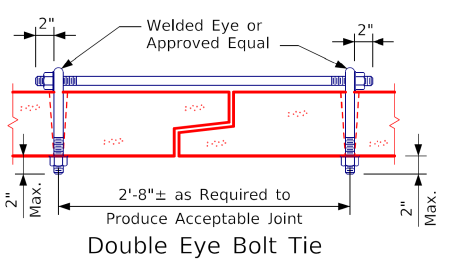

Double Eye Bolt Tie

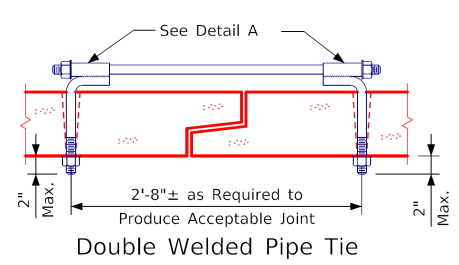

Double Welded Pipe Tie

Approved Concrete Box Ties

Note:
 Burr threads of Concrete Box Ties without damaging galvanizing to prevent nut rotation after tightening is complete.

* The connections shall be placed at the downstream end when the connections are placed inside of structure.

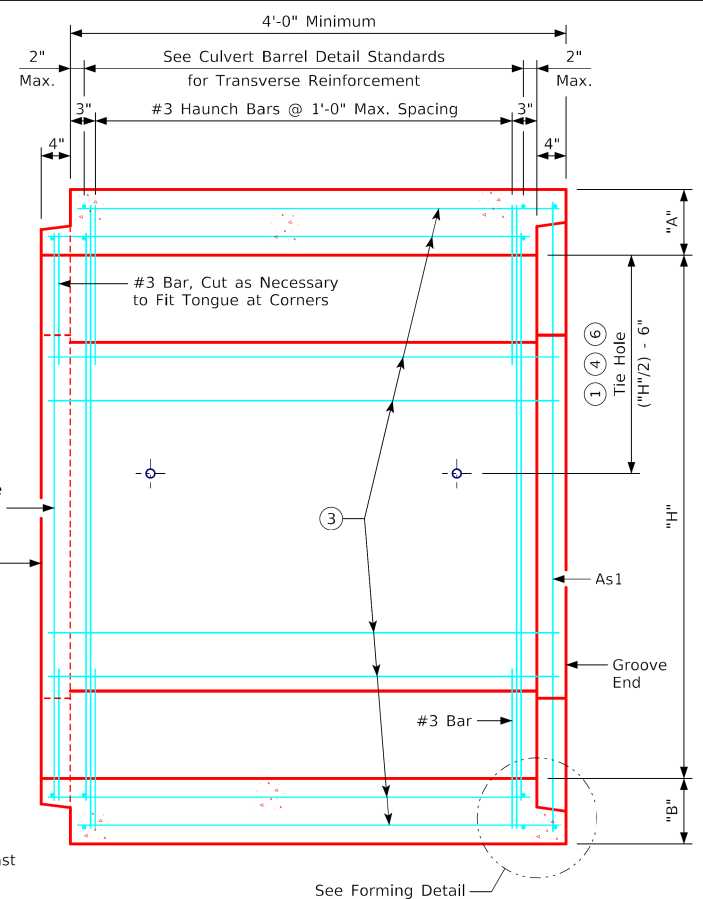

Longitudinal Barrel Section
 (Reinforcement Bar Option Shown)

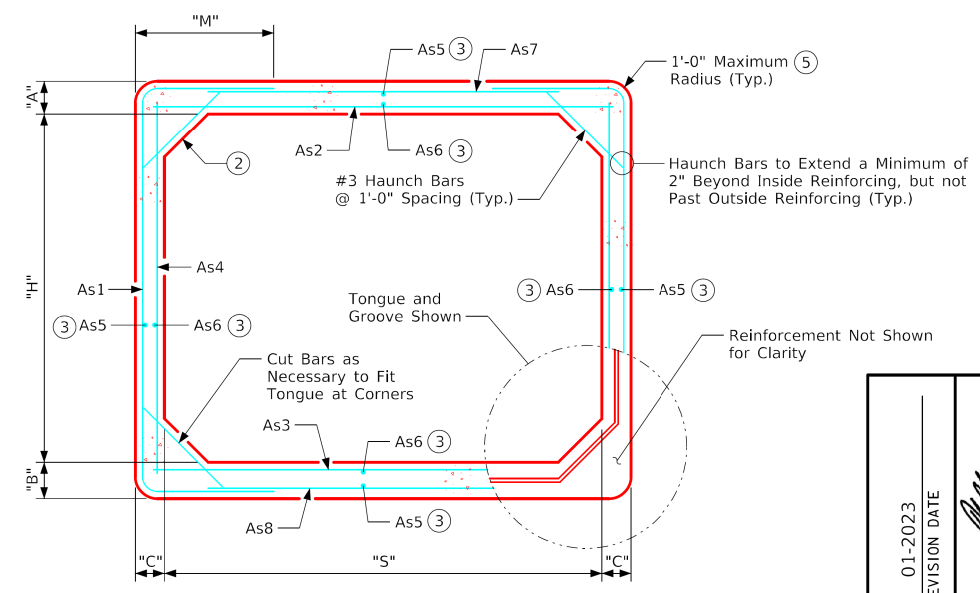

Transverse Barrel Section
 (Reinforcement Bar Option Shown)

Notes:

- ① Culvert ties are to be 1"Ø rods. See this sheet for connection details.
- ② Haunch sizes are to be 12" vertical, 12" horizontal on all box sizes.
- ③ Longitudinal reinforcement denoted as As5 & As6 must be placed in slab, floor, and walls and must be 0.06 IN.²/FT. MIN.
- ④ Refer to applicable end section detail sheet for barrel to end section connection tie hole locations.
- ⑤ Optional squared corners with 3/4" to 2" chamfer.
- ⑥ U bolt ties are required for cattle paths with nuts on fill side.

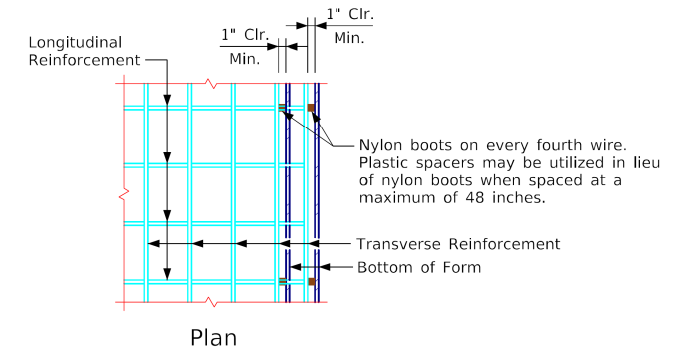

Plan

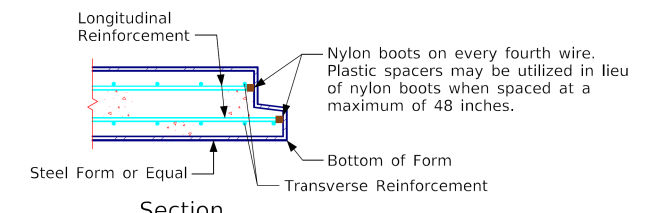

Section

Forming Detail

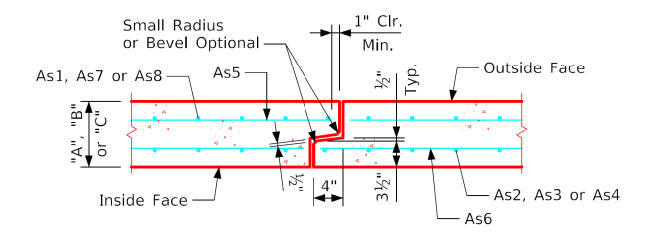

Tongue and Groove Joint Detail

01-2023 LATEST REVISION DATE APPROVED BY BRIDGE ENGINEER 	 Standard Design Single Precast Reinforced Concrete Box Culverts December, 2020	
	Typical Culvert Barrel Details	PRCB G2-20

NO.	REVISION DESCRIPTION	APPROVED	DATE

Variable Dimensions and Quantities for 16' Span Barrel Sections

Dimensions										Reinforcement Requirements								Weight (LB/FT)		
Size	Class	f'c (KSI)	Fill (FT)	S (FT)	H (FT)	A (IN)	B (IN)	C (IN)	Area (IN ² /FT)	Length	M	Area (IN ² /FT)	Length	Area (IN ² /FT)	Length	Area (IN ² /FT)	Length		Area (IN ² /FT)	Length
16'x4'	1	5.0	2-10	16	4	10	11	10	1.53	13'-5"	4'-2"	0.96	16'-6"	0.93	16'-6"	0.24	4'-6"	0.27	15'-8"	5940
	2	5.0	11-13	16	4	11	11	10	1.92	13'-2"	4'-0"	1.19	16'-6"	1.20	16'-6"	0.27	4'-6"	0.27	15'-8"	6160
	3	6.0	14-16	16	4	12	12	11	1.88	13'-2"	3'-11"	1.14	16'-6"	1.16	16'-6"	0.27	4'-6"	0.29	15'-10"	6750
16'x5'	1	5.0	2-8	16	5	10	11	9	1.37	13'-7"	3'-9"	0.99	16'-6"	0.98	16'-6"	0.23	5'-6"	0.27	15'-6"	6020
	2	5.0	9-12	16	5	11	11	10	1.62	13'-8"	3'-9"	1.17	16'-6"	1.20	16'-6"	0.24	5'-6"	0.27	15'-8"	6410
	3	5.0	13-16	16	5	12	12	11	1.77	13'-10"	3'-9"	1.28	16'-6"	1.31	16'-6"	0.27	5'-6"	0.29	15'-10"	7025
16'x6'	1	5.0	2-9	16	6	10	11	9	1.40	14'-3"	3'-7"	1.19	16'-6"	1.19	16'-6"	0.23	6'-6"	0.27	15'-6"	6245
	2	5.0	10-12	16	6	11	11	10	1.52	14'-4"	3'-7"	1.29	16'-6"	1.32	16'-6"	0.24	6'-6"	0.27	15'-8"	6660
	3	5.0	13-16	16	6	12	12	10	1.77	14'-0"	3'-4"	1.55	16'-6"	1.61	16'-6"	0.24	6'-6"	0.29	15'-8"	7100
16'x7'	1	5.0	2-9	16	7	10	11	9	1.32	14'-11"	3'-5"	1.29	16'-6"	1.32	16'-6"	0.23	7'-6"	0.27	15'-6"	6470
	2	5.0	10-12	16	7	11	11	9	1.56	14'-6"	3'-2"	1.55	16'-6"	1.61	16'-6"	0.23	7'-6"	0.27	15'-6"	6690
	3	6.0	13-16	16	7	12	12	10	1.59	14'-10"	3'-3"	1.68	16'-6"	1.73	16'-6"	0.24	7'-6"	0.29	15'-8"	7350
16'x8'	1	5.0	2-8	16	8	10	11	9	1.19	15'-9"	3'-4"	1.29	16'-6"	1.32	16'-6"	0.23	8'-6"	0.27	15'-6"	6695
	2	5.0	9-12	16	8	11	11	9	1.47	15'-4"	3'-1"	1.67	16'-6"	1.74	16'-6"	0.23	8'-6"	0.27	15'-6"	6915
	3	6.0	13-16	16	8	12	12	10	1.47	15'-8"	3'-2"	1.79	16'-6"	1.85	16'-6"	0.24	8'-6"	0.29	15'-8"	7600
16'x9'	1	5.0	2-8	16	9	10	11	8	1.23	16'-1"	3'-0"	1.55	16'-6"	1.59	16'-6"	0.20	9'-6"	0.27	15'-4"	6650
	2	5.0	9-12	16	9	11	11	9	1.40	16'-4"	3'-1"	1.79	16'-6"	1.88	16'-6"	0.23	9'-6"	0.27	15'-6"	7140
	3	6.0	13-16	16	9	12	12	9	1.40	16'-2"	2'-11"	2.07	16'-6"	2.16	16'-6"	0.23	9'-6"	0.29	15'-6"	7575
16'x10'	1	5.0	2-8	16	10	10	11	8	1.20	17'-1"	3'-0"	1.65	16'-6"	1.71	16'-6"	0.20	10'-6"	0.27	15'-4"	6850
	2	5.0	9-12	16	10	11	11	9	1.35	17'-4"	3'-1"	1.91	16'-6"	2.00	16'-6"	0.23	10'-6"	0.27	15'-6"	7365
	3	6.0	13-16	16	10	12	12	10	1.31	17'-6"	3'-1"	2.00	16'-6"	2.09	16'-6"	0.24	10'-6"	0.29	15'-8"	8100
16'x11'	1	5.0	2-8	16	11	10	11	8	1.20	18'-1"	3'-0"	1.76	16'-6"	1.83	16'-6"	0.20	11'-6"	0.27	15'-4"	7050
	2	5.0	9-12	16	11	11	11	9	1.32	18'-6"	3'-2"	2.00	16'-6"	2.13	16'-6"	0.23	11'-6"	0.27	15'-6"	7590
	3	6.0	13-16	16	11	12	12	10	1.28	18'-8"	3'-2"	2.09	16'-6"	2.21	16'-6"	0.24	11'-6"	0.29	15'-8"	8350
16'x12'	1	5.0	2-7	16	12	10	11	8	1.17	19'-7"	3'-3"	1.76	16'-6"	1.83	16'-6"	0.24	12'-6"	0.27	15'-4"	7250
	2	5.0	8-11	16	12	11	11	9	1.22	20'-0"	3'-5"	1.97	16'-6"	2.12	16'-6"	0.23	12'-6"	0.27	15'-6"	7815
	3	6.0	12-16	16	12	12	12	11	1.22	20'-6"	3'-7"	2.00	16'-6"	2.15	16'-6"	0.27	12'-6"	0.29	15'-10"	8950
16'x13'	1	5.0	2-7	16	13	10	11	8	1.20	21'-7"	3'-9"	1.86	16'-6"	1.95	16'-6"	0.32	13'-6"	0.27	15'-4"	7450
	2	5.0	8-11	16	13	11	11	9	1.23	21'-6"	3'-8"	2.06	16'-6"	2.24	16'-6"	0.27	13'-6"	0.27	15'-6"	8040
	3	6.0	12-16	16	13	12	12	11	1.19	21'-10"	3'-9"	2.10	16'-6"	2.25	16'-6"	0.29	13'-6"	0.29	15'-10"	9225
16'x14'	1	5.0	2-7	16	14	10	11	8	1.23	24'-3"	4'-7"	2.00	16'-6"	2.09	16'-6"	0.42	14'-6"	0.27	15'-4"	7650
	2	5.0	8-11	16	14	11	11	10	1.22	23'-4"	4'-1"	1.98	16'-6"	2.16	16'-6"	0.31	14'-6"	0.27	15'-8"	8660
	3	6.0	12-16	16	14	12	12	11	1.17	23'-2"	3'-11"	2.19	16'-6"	2.37	16'-6"	0.29	14'-6"	0.29	15'-10"	9500

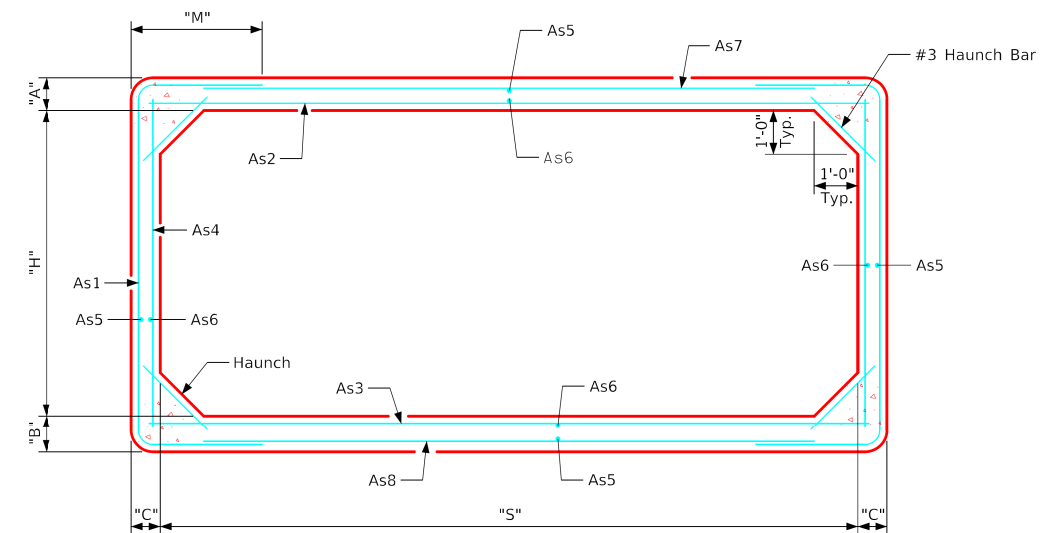

Typical Barrel Section

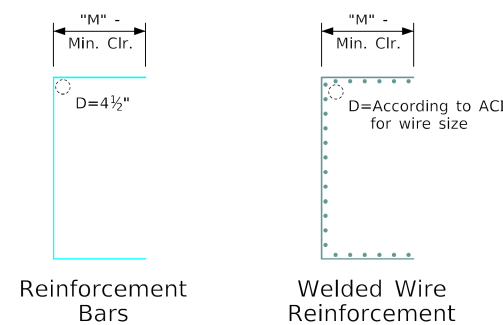

Bent Bar Details

All dimensions are out to out.
D = pin diameter (min.).
Pin diameter may be increased if needed to maintain clear cover.

Notes:

1. Longitudinal reinforcement denoted as As5 and As6 must be placed in slab, floor, and walls and must be 0.06 in²/ft minimum.
2. All reinforcement lengths and areas are minimum requirements.
3. If reinforcing bars are substituted for welded wire reinforcing, dimension "M" and/or length of the As7/As8 reinforcement shall be adjusted to ensure adequate lap length is provided.
4. Weight of sections assumes a density of 150 PCF and squared corners.
5. See PRCB G1-20 and G2-20 for additional information and notes.

10-2021 LATEST REVISION DATE	APPROVED BY BRIDGE ENGINEER	Standard Design Single Precast Reinforced Concrete Box Culverts December, 2020	PRCB 16-20
	Culvert Barrel Details 16'-0" Span Barrel Sections		
	VOLGA RIVER STATE RECREATION AREA HILL ROAD BRIDGE REPLACEMENT		

REVISED 10-2021: Updated Note 1 & Variable Dimension Table.
 ENGLISHIGNEDPRECASTCULVERTS.DGN - PRCB 16-20 - THIS SHEET ISSUED 12-2020.

12/28/2022 12:40:07 PM bkloss pw:\NTP\int1.dot.int.lan:PwMain\Documents\Highway\Bridges\Standards Development V81\Culverts\EnglishSignedPrecastCulverts.dgn PRCB 16-20 11x17.pdf.pltcf

NO.	REVISION DESCRIPTION	APPROVED	DATE

M:\Manzer P:\Projects\DM2142305960\Deliverables\Drawings1_Civil\PlansV_Bridge and Culvert Situation PlansV-SHEETS.dgn 11/14/2024 3:00:20 PM

REVISED 10-2021: Updated curtain wall height & added lintel beam connection hole location in Plan View. Updated wall thickness & added note reference for floor thickness in End View.
 ENGLISHIGNEDPRECASTCULVERTS.DGN - PES 7-20-T3 S1 - THIS SHEET ISSUED 12-2020.

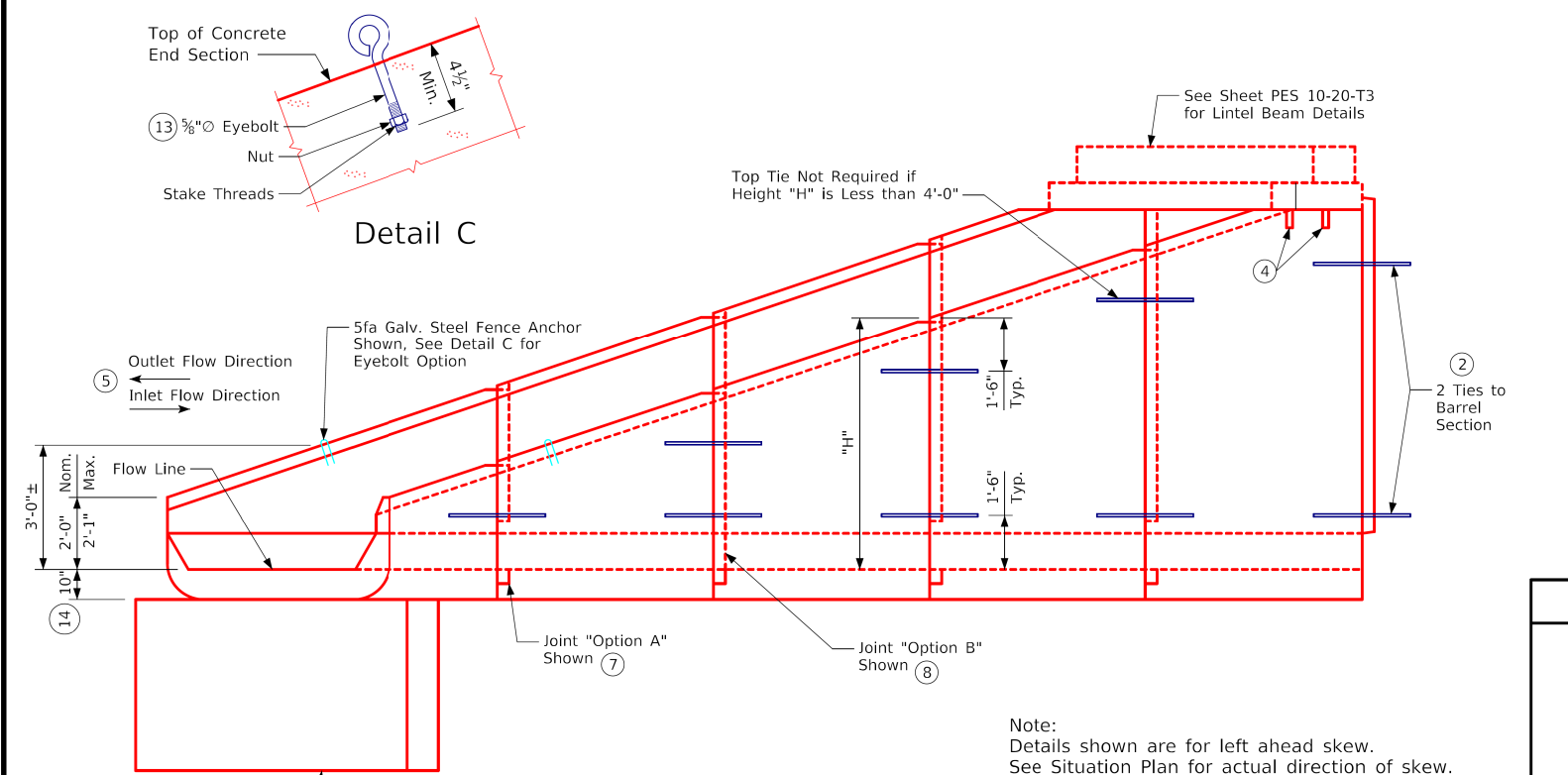
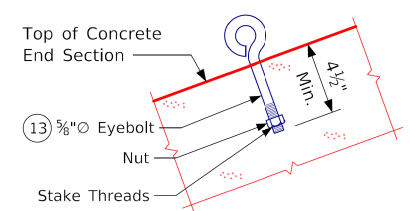
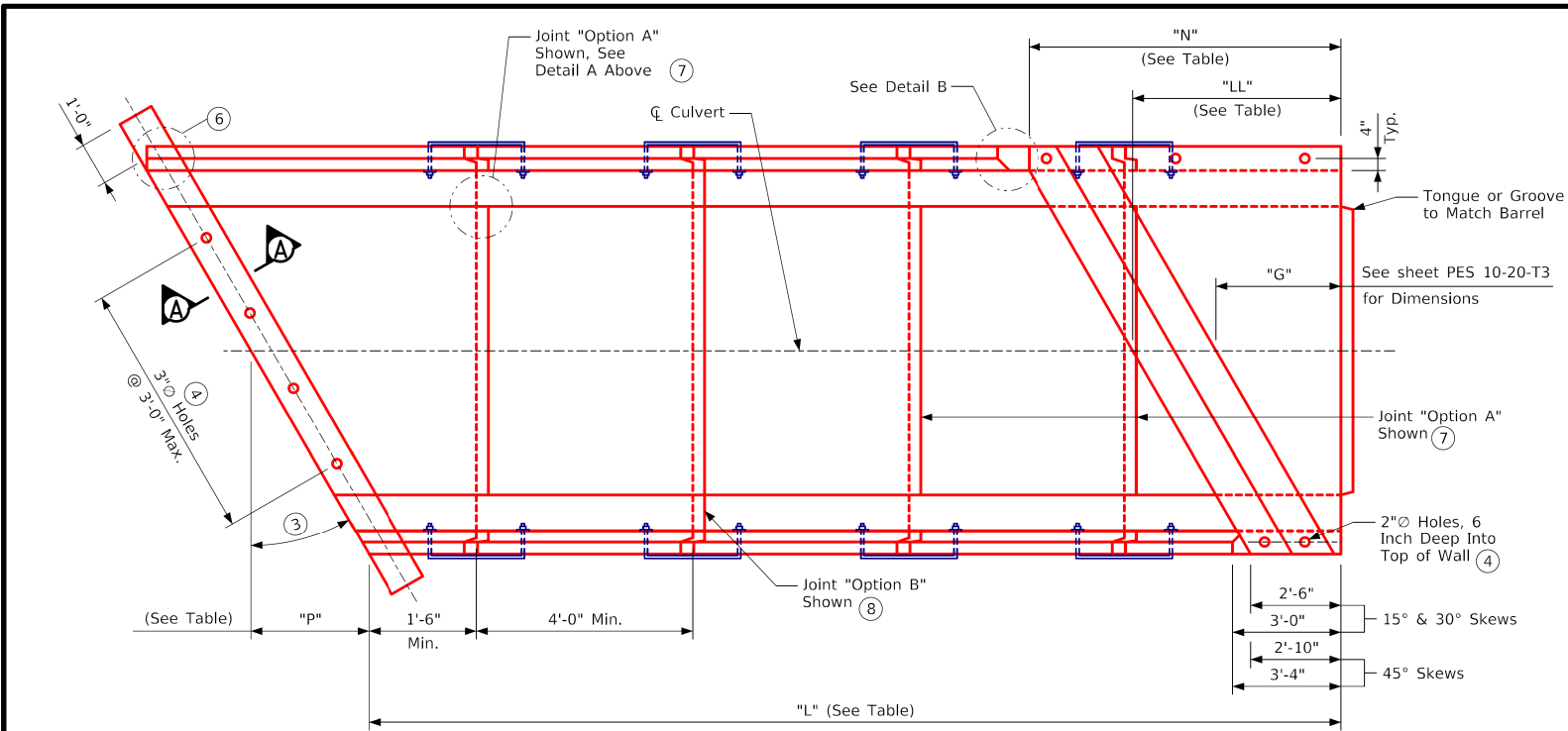

Note:
 Details shown are for left ahead skew.
 See Situation Plan for actual direction of skew.
 Details for right ahead skews similar.
 See sheet PES 8-20-T3 for additional information
 and notes used in conjunction with this sheet.

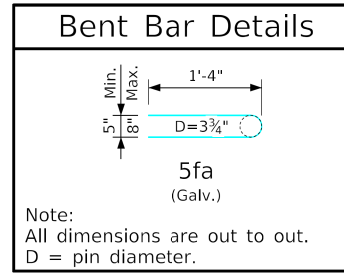
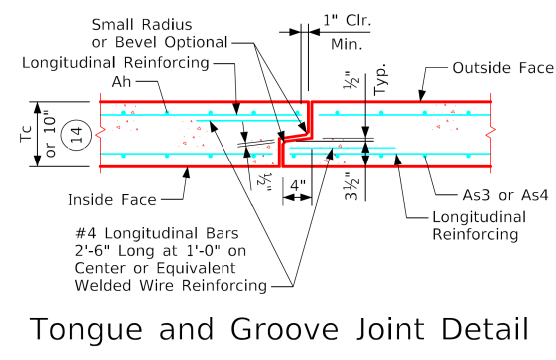
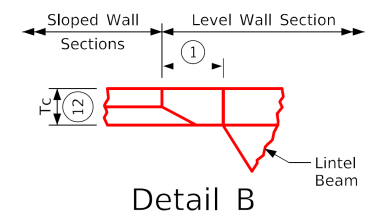
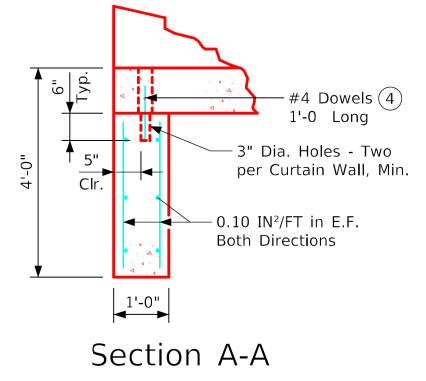
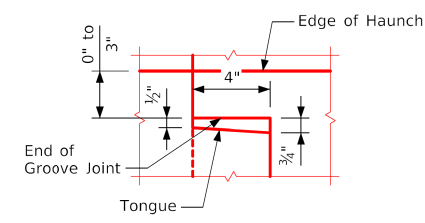
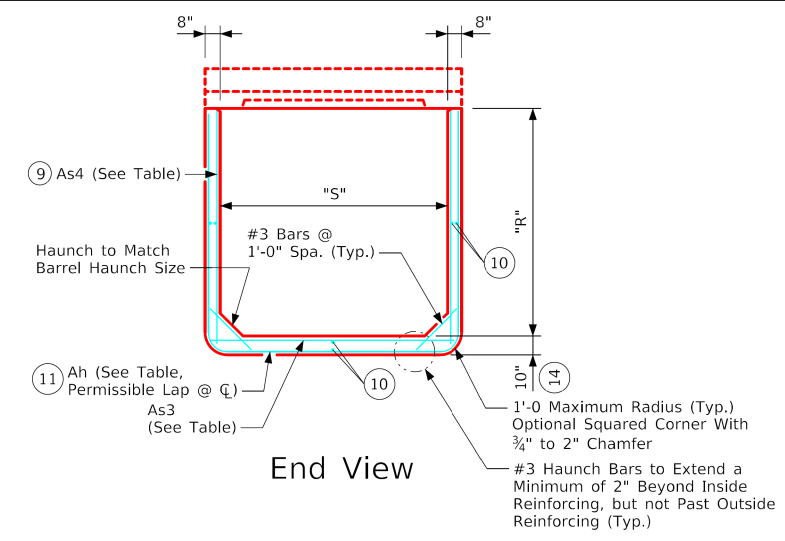

10-2021
 LATEST REVISION DATE

IOWADOT
 Standard Design
Single Precast Reinforced Concrete Box Culverts
 December, 2020

Type 3 End Section Details
 For Skews of 7.5° to 45°; 14'-16' Spans

PES 7-20-T3
 Sheet 1 of 2

12/28/2022 12:40:29 PM bkloss p:\NTP\int1.dot.int.lan:P\Main\Documents\Highway\Bridges\Standards Development V8\1\Culverts\EnglishSignedPrecastCulverts.dgn PES 7-20-T3 11x17.pdf.pltcfp

NO.	REVISION DESCRIPTION	APPROVED	DATE

REVISED 10-2021: Updated Note 10 & 12 and added Note 14. Updated As4 Reinforcing Table for H = 13' & 14'.
 REVISED 01-2023: Added note to burr threads of Concrete Box Ties.
 ENGLISH SIGNED PRECAST CULVERTS.DGN - PES 8-20-T3 S2 - THIS SHEET ISSUED 12-2020.

Dimens.		Ah & As3 Reinforcement				
Span S (FT)	Section Ht. H (FT)	Required Ah (IN ² /FT)			Required As3 (IN ² /FT)	
		15° Skew	30° Skew	45° Skew		
14	4	0.24	0.24	0.24	0.24	
	5	0.24	0.24	0.24	0.24	
	6	0.24	0.24	0.24	0.24	
	7	0.24	0.24	0.24	0.24	
	8	0.25	0.26	0.28	0.28	
	9	0.37	0.40	0.42	0.36	
	10	0.53	0.57	0.60	0.45	
	11	0.73	0.78	0.83	0.55	
	12	0.97	1.05	1.10	0.68	
	13	1.06	1.13	1.20	0.86	
	14	1.32	1.42	1.50	1.03	
	16	4	0.24	0.24	0.24	0.24
		5	0.24	0.24	0.24	0.24
		6	0.24	0.24	0.24	0.24
7		0.24	0.24	0.24	0.24	
8		0.25	0.26	0.28	0.30	
9		0.37	0.40	0.42	0.38	
10		0.53	0.57	0.60	0.47	
11		0.73	0.78	0.83	0.58	
12		0.97	1.05	1.10	0.71	
13		1.06	1.14	1.20	0.89	
14		1.33	1.42	1.50	1.07	

Note: "H" is the largest vertical dimension of the section.

Length LL				
Span S (FT)	Tc (IN.)	15° Skew	30° Skew	45° Skew
14	8	4'-7"	6'-11"	10'-6"
	9	4'-7"	7'-0"	10'-7"
16	8	4'-10"	7'-6"	11'-6"
	9	4'-10"	7'-7"	11'-7"

Length N				
Span S (FT)	Tc (IN.)	15° Skew	30° Skew	45° Skew
14	8	6'-5"	11'-0"	17'-6"
	9	6'-5"	11'-1"	17'-7"
16	8	7'-0"	12'-1"	19'-6"
	9	7'-0"	12'-2"	19'-7"

Length P				
Span S (FT)	Tc (IN.)	15° Skew	30° Skew	45° Skew
14	8	2'-1"	4'-5"	7'-8"
	9	2'-1"	4'-6"	7'-9"
16	8	2'-4"	5'-0"	8'-8"
	9	2'-4"	5'-1"	8'-9"

Note: Dimensions shown in tables are rounded to the nearest whole inch.

As4 Reinf. (IN ² /FT)			
Section Ht. H (FT)	15° Skew	30° Skew	45° Skew
10 or Less	0.20	0.20	0.20
11	0.20	0.21	0.22
12	0.25	0.27	0.29
13	0.32	0.34	0.36
14	0.40	0.42	0.45

Note: As4 is inside face wall steel for the first section adjacent to the barrel only. "H" is the largest vertical dimension of the section. For all other sections, As4 = 0.20 IN²/FT

Length L			
Rise R (FT)	15° Skew	30° Skew	45° Skew
4	9'-3"	9'-11"	12'-2"
5	12'-4"	13'-5"	16'-5"
6	15'-5"	16'-10"	20'-8"
7	18'-6"	20'-4"	24'-11"
8	21'-8"	23'-9"	29'-1"
9	24'-9"	27'-3"	33'-4"
10	27'-10"	30'-9"	37'-7"
11	30'-11"	34'-2"	41'-10"
12	34'-1"	37'-8"	46'-1"
13	37'-2"	41'-1"	50'-4"
14	40'-3"	44'-7"	54'-7"

"L" - Based on 3:1 foreslope normal to ϕ of roadway.

Construction Notes:

- Precast box culvert end sections shall be constructed in accordance with details and notes, as shown below:
- Reinforcing for precast end sections & curtain walls shall be welded wire reinforcing (WWR) meeting the requirements of AASHTO LRFD Section 5. The concrete cover over the reinforcing steel shall not be less than 1.5 inches or greater than 2.0 inches.
- Refer to sheets PRCB G1-20 & PRCB G2-20 for additional notes and details.
- Refer to "Fabric Layer Detail" on sheet PRCB G2-20 for multiple WWR layers.
- Burr threads of Concrete Box Ties without damaging galvanizing to prevent nut rotation after tightening is complete.

- 8 1/8" @ 15° ; 10 3/8" @ 30° ; 1'-2" @ 45°
- Culvert ties are to be 1 inch dia. rods.
- For skew angles over 7°30' up to 22°30', use a 15° skew end section. For skew angles over 22°30' up to 37°30', use a 30° skew end section. For skew angles over 37°30' up to 45°, use a 45° skew end section.
- Fill holes with grout. Grout shall consist of 1 part cement and 2 parts sand. Use air entrained portland cement. Grout mix shall have a maximum slump of 4 inches.
- Use tongue on inlet end section and groove on outlet end section.
- End of wall may be cut square as shown or follow the skew.
- Joint "Option A": Provide joint in walls and floor. Terminate joint at haunch. See "Detail A" on Sheet PES 7-20-T3.
- Joint "Option B": Provide continuous joint in walls, floor and haunch.
- For the first section adjacent to the barrel, see As4 table.
- Minimum longitudinal reinforcement shall be 0.06 sq. inches per peripheral foot on all faces of the end section, except in the tongue and groove area.
- Lap splices shall be Class B and shall be designed according to the AASHTO LRFD Bridge Design Specifications, Section 5.
- Wall thickness (Tc) shall be 8 inches when the Section Height (H) is less than or equal to 12 feet. For "H" equal to 13 to 14 feet, wall thickness shall be 9 inches.
- Optional eyebolts shall conform to ASTM A307. Eyebolts and nuts shall be galvanized in accordance with ASTM A153. The eye of the eyebolt shall be cast flush with the concrete surface.
- Bottom slab thickness may be increased up to 2" max. provided cover is 1 1/2" min. to 2" max.

Dowel Setting Note (Fence Anchor):

The 5fa bars or eyebolt may be set as dowels in drilled holes. Holes shall be drilled to the depth required to achieve bar embedment as shown in the "Elevation" or "Detail C". The dowels shall be installed in accordance with the Manufacturer's recommendations. Either of the following systems may be used as a bonding agent:

- Polymer grout system shall be in accordance with Article 2301.03, E, of the Standard Specifications.
- Hydraulic cement grout systems. Drilled holes are to be 2 1/2 times the dowel diameter and are to be blown clean with compressed air immediately prior to placing grout. The hydraulic cement grout shall be one of those approved in Materials I.M. 491.13.

Note: See sheet PES 7-20-T3 for details used in conjunction with this sheet.

01-2023 LATEST REVISION DATE	APPROVED BY BRIDGE ENGINEER		
		Standard Design Single Precast Reinforced Concrete Box Culverts December, 2020	
		Type 3 End Section Details	PES 8-20-T3 Sheet 2 of 2

NO.	REVISION DESCRIPTION	APPROVED	DATE

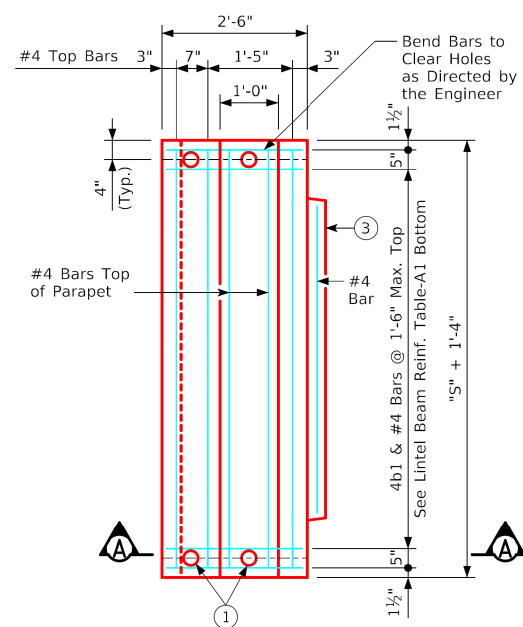

Plan of Square Lintel Beam
(Tongue Option Shown)

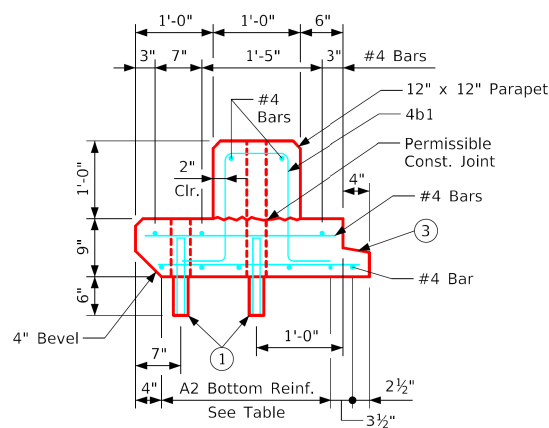

Section A-A
(Tongue Option Shown)

0° Skew Lintel Beam
(For Skews up to 7°30')

Span S (FT)	Lintel Beam Reinforcement			
	Bottom Reinforcement			
	WWR Option		Rebar Option	
	A1 (IN ² /FT)	A2 (IN ² /FT)	A1	A2
6	0.13	0.26	#4 @ 12"	3 - #4 @ 12"
8	0.16	0.32	#4 @ 12"	4 - #4 @ 8"
10	0.20	0.40	#4 @ 12"	3 - #5 @ 12"
12	0.25	0.49	#5 @ 12"	4 - #5 @ 8"

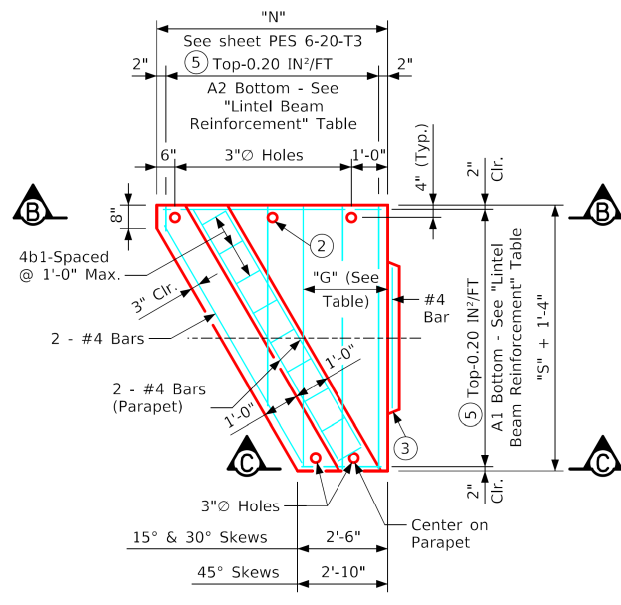

Plan View

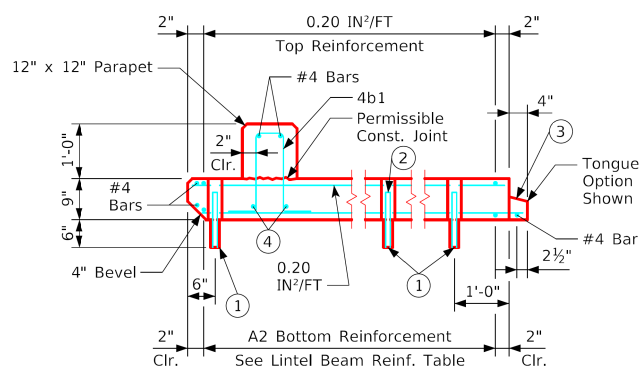

Section B-B

Skewed Lintel Beam
(For Skews of 7°30' to 45°)

Span S (FT)	Length G Along Barrel C of Skewed Lintel Beam		
	15° Skew	30° Skew	45° Skew
6	1'-4 ¹³ / ₁₆ "	2'-3 ¹¹ / ₁₆ "	3'-8 ¹ / ₁₆ "
8	1'-8 ³ / ₁₆ "	2'-10 ³ / ₁₆ "	4'-8 ¹ / ₁₆ "
10	1'-11 ³ / ₁₆ "	3'-5 ⁹ / ₁₆ "	5'-8 ¹ / ₁₆ "
12	2'-2 ³ / ₁₆ "	4'-0 ¹ / ₂ "	6'-8 ¹ / ₁₆ "

Span S (FT)	Lintel Beam Reinforcement			
	Bottom Reinforcement			
	WWR Option		Rebar Option	
	A1 (IN ² /FT)	A2 (IN ² /FT)	A1	A2
6	0.28	0.55	#5 @ 12"	#5 @ 6"
8	0.38	0.76	#6 @ 12"	#6 @ 6"
10	0.50	1.00	#7 @ 12"	#7 @ 6"
12	0.65	1.30	#8 @ 12"	#8 @ 6"

Span S (FT)	Skewed Parapet Reinforcement		
	Bottom Reinforcement		
	15° Skew	30° Skew	45° Skew
6	2 - #5	2 - #6	2 - #6
8	2 - #6	2 - #6	2 - #7
10	2 - #7	2 - #7	2 - #8
12	2 - #7	2 - #8	3 - #8

Notes:

- Precast lintel beams shall be constructed in accordance with precast barrel and end section details and notes, except as modified below.
- Reinforcing for precast lintels and parapets shall be either welded wire reinforcing (WWR) meeting the requirements of AASHTO LRFD Section 5 or reinforcing bars meeting the requirements of ASTM A615 (60 KSI). Wire spacing for WWR shall not exceed 4 inches for primary steel and 8 inches for distribution steel.
- Place #8 dowel, 1'-0" long into 2 inch dia. hole in the top of the wall section and 3 inch dia. hole in the lintel beam. Fill holes with grout.
- Cast additional 3 inch holes to maintain a 4 foot maximum hole spacing.
- Check the location to determine whether a tongue or a groove is used. Tongue and groove to terminate at culvert radius.
- See "Skewed Parapet Reinforcement" table.
- Areas shown are for welded wire fabric. If rebar is used, #4 at a max. of 11 inch spacing should be used.

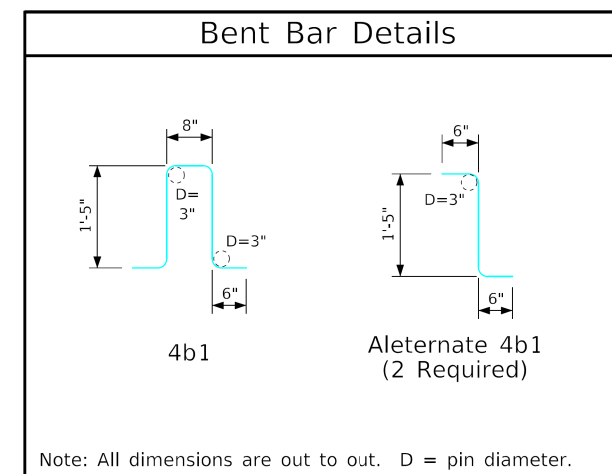

ENGLISHIGNEDPRECASTCULVERTS.DGN - PES 9-20-T3 - THIS SHEET ISSUED 12-2020.

MManzer P:\Projects\DM2142305960\Deliverables\Drawings1_Civil\plansV_Bridge and Culvert Situation PlansV-SHEETS.dgn 11/4/2024 3:00:36 PM

12/28/2022 12:40:33 PM bkloss pw:\NTP\int1.dot.int.lan:PwMain\Documents\Highway\Bridges\Standards Development V81\Culverts\EnglishSignedPrecastCulverts.dgn PES 9-20-T3 11x17.pdf.pltcf

NO.	REVISION DESCRIPTION	APPROVED	DATE

IOWA DOT

Standard Design
**Single Precast Reinforced
Concrete Box Culverts**
December, 2020

**Type 3 Lintel
Beam Details**
For Skews 0° to 45°; 6' - 12' Spans

PES 9-20-T3

LATEST REVISION DATE

APPROVED BY BRIDGE ENGINEER

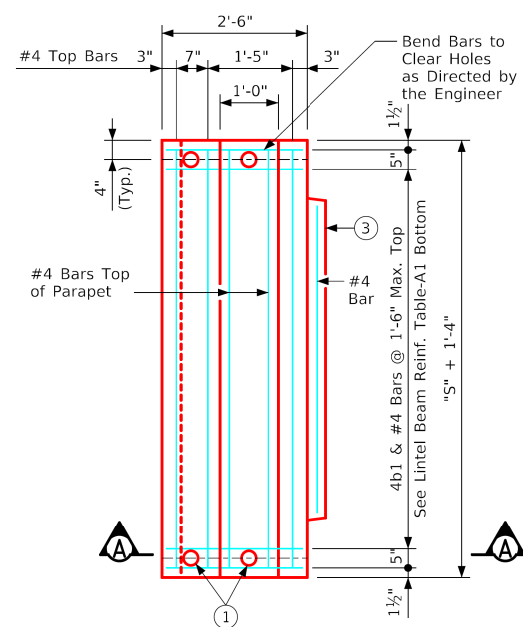

Plan of Square Lintel Beam
(Tongue Option Shown)

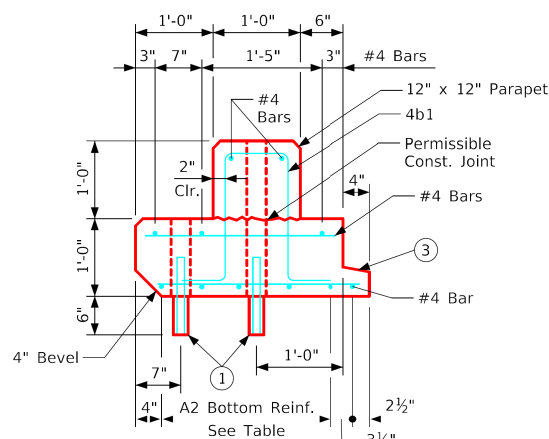

Section A-A
(Tongue Option Shown)
0° Skew Lintel Beam
(For Skews up to 7°30')

Span S (FT)	Lintel Beam Reinforcement			
	Bottom Reinforcement			
	WWR Option		Rebar Option	
	A1 (IN ² /FT)	A2 (IN ² /FT)	A1	A2
14	0.26	0.51	#5 @ 12"	4 - #5 @ 8"
16	0.30	0.59	#5 @ 12"	5 - #5 @ 6"

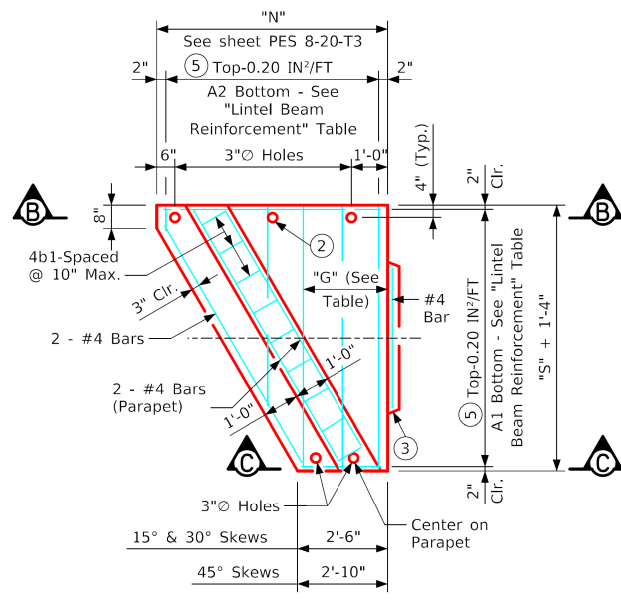

Plan View

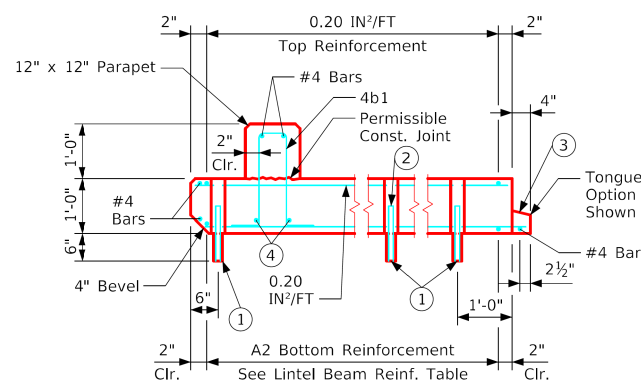

Section B-B
Skewed Lintel Beam
(For Skews of 7°30' to 45°)

Span S (FT)	Length G (14' - 16' Spans) Along Barrel C of Skewed Lintel Beam			
	Box Rise	15° Skew	30° Skew	45° Skew
14	4' to 12'	2'-5 ¹³ / ₁₆ "	4'-7 ⁷ / ₁₆ "	7'-8 ¹ / ₁₆ "
	13' & 14'	2'-6 ³ / ₁₆ "	4'-8"	7'-9 ⁹ / ₁₆ "
16	4' to 12'	2'-9"	5'-2 ⁹ / ₁₆ "	8'-8 ⁸ / ₁₆ "
	13' & 14'	2'-9 ⁹ / ₁₆ "	5'-2 ¹⁵ / ₁₆ "	8'-9 ³ / ₁₆ "

Span S (FT)	Lintel Beam Reinforcement			
	Bottom Reinforcement			
	WWR Option		Rebar Option	
	A1 (IN ² /FT)	A2 (IN ² /FT)	A1	A2
14	0.56	1.12	#7 @ 12"	#7 @ 6"
16	0.73	1.46	#8 @ 12"	#8 @ 6"

Span S (FT)	Skewed Parapet Reinforcement		
	15° Skew	30° Skew	45° Skew
14	2 - #8	3 - #7	3 - #8
16	2 - #8	2 - #9	3 - #9

Notes:

- Precast lintel beams shall be constructed in accordance with precast barrel and end section details and notes, except as modified below.
- Reinforcing for precast lintels and parapets shall be either welded wire reinforcing (WWR) meeting the requirements of AASHTO LRFD Section 5 or reinforcing bars meeting the requirements of ASTM A615 (60 KSI). Wire spacing for WWR shall not exceed 4 inches for primary steel and 8 inches for distribution steel.
- Place #8 dowel, 1'-0" long into 2 inch dia. hole in the top of the wall section and 3 inch dia. hole in the lintel beam. Fill holes with grout.
- Cast additional 3 inch holes to maintain a 4 foot maximum hole spacing.
- Check the location to determine whether a tongue or a groove is used. Tongue and groove to terminate at culvert radius.
- See "Skewed Parapet Reinforcement" table.
- Areas shown are for welded wire fabric. If rebar is used, #4 at a max. of 11 inch spacing should be used.

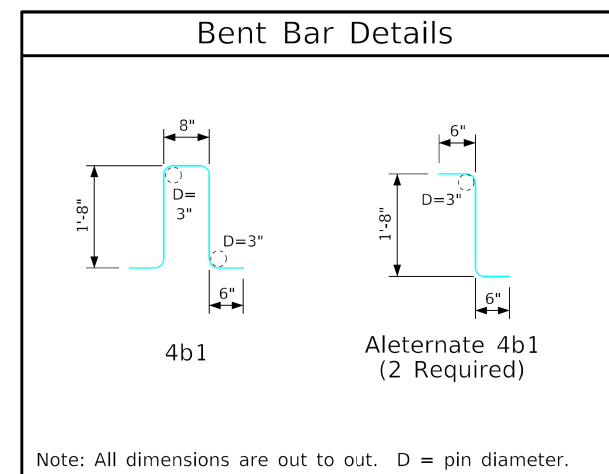

Note: All dimensions are out to out. D = pin diameter.

REVISED 10-2021: Updated width dimension on Plan of Square Lintel Beam & Plan View of Skewed Lintel Beam. ENGLISHIGNEDPRECASTCULVERTS.DGN - PES_10-20-T3 - THIS SHEET ISSUED 12-2020.

M:\Manzer P:\Projects\DM2142305960\Deliverables\Drawings1_Civil\plans\Bridg and Culvert Situation Plans\V-SHEETS.dgn 11/14/2024 3:00:44 PM

12/28/2022 12:40:35 PM bkloss p:\NTP\int1.dot.int.lan:PwMain\Documents\Highway\Bridg\Standards Development V81\Culverts\EnglishSignedPrecastCulverts.dgn PES_10-20-T3 11x17.pdf.pltcfgr

NO.	REVISION DESCRIPTION	APPROVED	DATE

10-2021 LATEST REVISION DATE

APPROVED BY BRIDGE ENGINEER

IOWA DOT

Standard Design
Single Precast Reinforced Concrete Box Culverts
December, 2020

Type 3 Lintel Beam Details
For Skews 0° to 45°; 14' - 16' Spans

PES 10-20-T3

M:\Manzer P:\Projects\DM2142305960\Deliverables\Drawings1_Civil\PlansV_Bridge and Culvert Situation PlansV-SHEETS.dgn 11/4/2024 3:00:51 PM

ENGLISHIGNEDPRECASTCULVERTS.DGN - PES 11-20 - THIS SHEET ISSUED 12-2020.

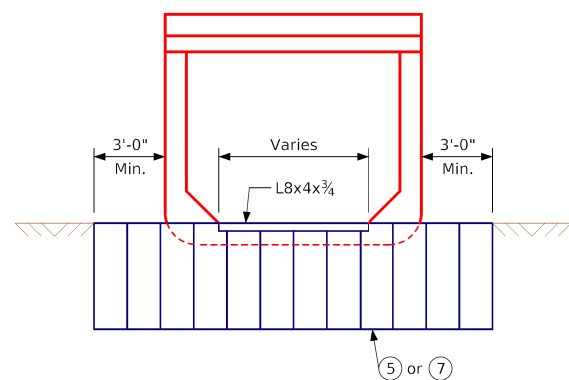

End View

Alternates 1 & 2 (Galvanized Steel Sheet Piling)

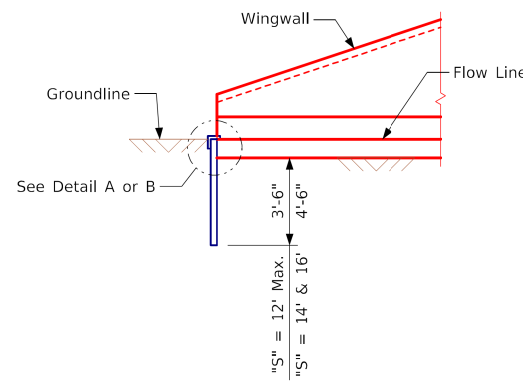

Elevation

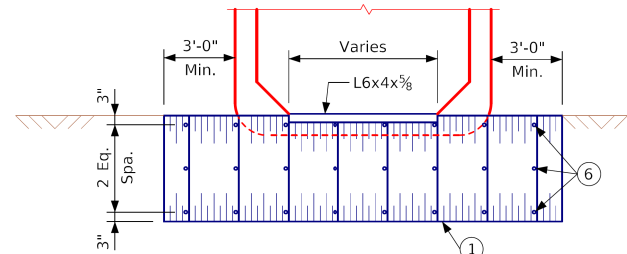

End View

Alternates 3 & 4 (Galvanized Steel Sheets)

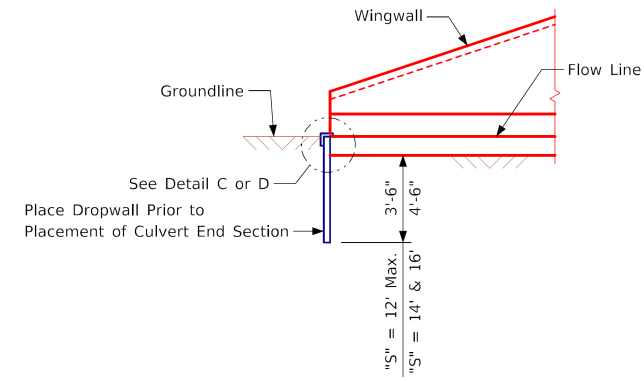

Elevation

Notes:

Use of alternate curtain walls shall be approved by the Engineer.

All curtain wall material, including bolts, nuts, washers, and angles shall be galvanized per I.D.O.T. Standard Specifications. Bolts, nuts and washers shall conform to Article 4153.06, A, of the I.D.O.T. Standard Specifications.

- ① 2 1/2"x1/2" or 2"x1/2" corrugated (12 gauge or heavier) galvanized steel sheets.
- ② Fasten the steel sheets to the front edge of the apron with 3/8"Øx4" bolts and approved anchorages (10" center to center, to the nearest valley). Anchors shall have a minimum pull out strength of 2000 pounds based on 4000 psi concrete.
- ③ Fasten the L8"x4"x3/4" or L6"x4"x3/8" with 3/8"Øx4" bolts, 1" O.D. washer and an approved anchorage (2'-0" spacing). Anchors shall have a minimum pull out strength of 2000 pounds based on 4000 psi concrete.
- ④ Fasten the steel sheets to the front edge of the apron with 3/8"Øx5" cast-in-place bolts with nut and lock washer (10" center to center, to the nearest valley).
- ⑤ Galvanized corrugated (12 gauge or heavier) steel sheet piling, interlocking Type A.
- ⑥ 3/8"Øx1" bolt with nut, to lap steel sheets.
- ⑦ Galvanized steel sheet piling, section PS 27.5 or equal.
- ⑧ Fill the voids as shown, with Class O concrete or concrete grout, as approved by the Engineer.
- ⑨ Caulk joint between top of end section floor and angle. Caulking material shall be neutral cure and non-sag silicone. Three products meeting these criteria are Dow 888, CSL 342 joint sealant, and Crafcro Road Saver Silicone.
- ⑩ A bent plate may be provided as an alternate to the angle. The bent plate shall match the angle dimensions shown.

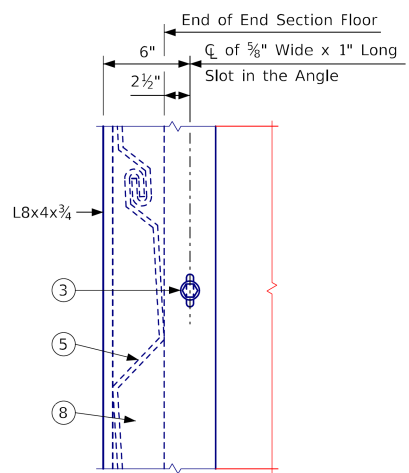

Plan

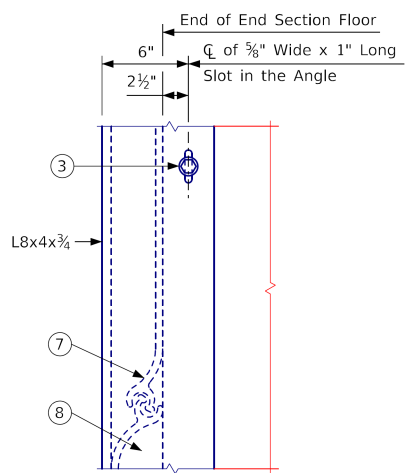

Plan

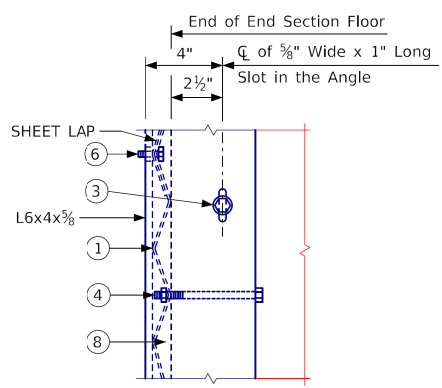

Plan

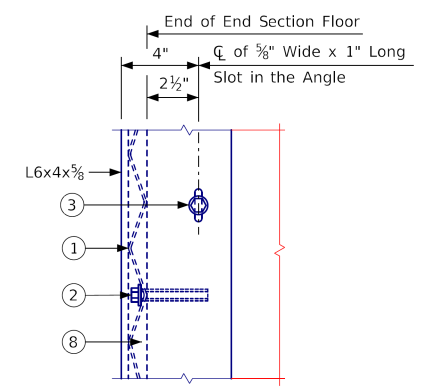

Plan

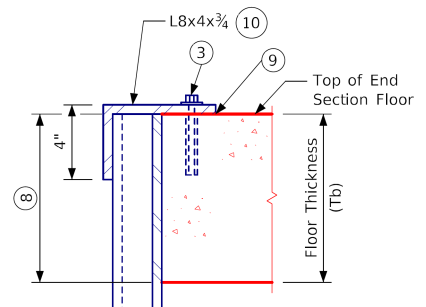

Elevation

**Detail A
Alternate 1**
Steel Sheet Piling Shown;
Allowed on New & Old Construction

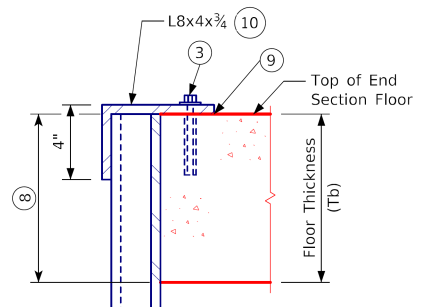

Elevation

**Detail B
Alternate 2**
Steel Sheet Piling Shown;
Allowed on New & Old Construction

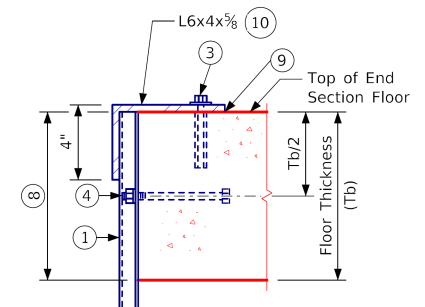

Elevation

**Detail C
Alternate 3**
Corrugated Sheets Shown;
Allowed on New Construction Only

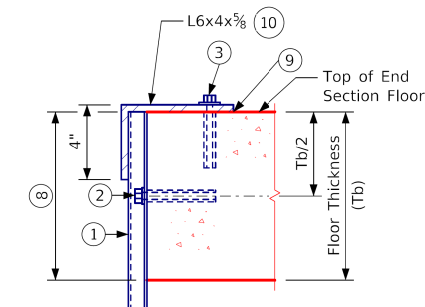

Elevation

**Detail D
Alternate 4**
Corrugated Sheets Shown;
Allowed on New Construction Only

LATEST REVISION DATE	 APPROVED BY BRIDGE ENGINEER	 Standard Design Single Precast Reinforced Concrete Box Culverts December, 2020	
		Alternate Curtain Wall Details	PES 11-20
		VOLGA RIVER STATE RECREATION AREA HILL ROAD BRIDGE REPLACEMENT	

12/28/2022 12:40:38 PM bkloss pw:\NTP\int1.dot.int.lan:PwMain\Documents\Highway\Bridges\Standards Development V81\Culverts\EnglishSignedPrecastCulverts.dgn PES 11-20 11x17_pdf.pltcfgr

NO.	REVISION DESCRIPTION	APPROVED	DATE